

# GP600 GENERAL PURPOSE CONFIGURABLE RACKMOUNT SYSTEM

## GP600 OVERVIEW

The GP600 is a flexible rackmount system that can be built with any combination of fiber optic device, such as Optical Switches, WDMs, VOAs, Couplers, Tap Detectors, Transceivers, Delays, EDFAs, Fast Receivers, Tunable Filters, etc.

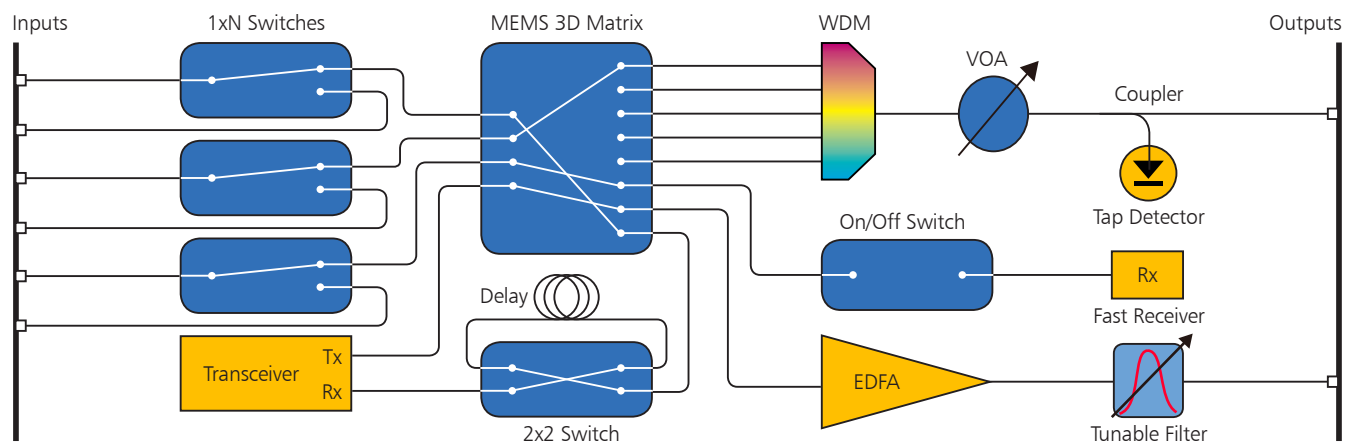
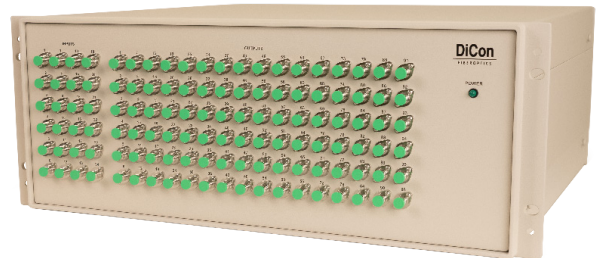

## FEATURES

- Control via a single interface
- Expertly built-to-order
- Available in custom configurations

## APPLICATIONS

- Test & Measurement
- Fiber Monitoring
- Commercial & Defense Networks



1689 Regatta Blvd.  
Richmond, CA 94804  
(510) 620-5200  
[www.diconfiberoptics.com](http://www.diconfiberoptics.com)

**Commercial Business**  
[sales@diconfiberoptics.com](mailto:sales@diconfiberoptics.com)  
**US Government Business**  
[sales@diconusa.com](mailto:sales@diconusa.com)

# GP600 GENERAL PURPOSE CONFIGURABLE RACKMOUNT SYSTEM

## MULTIMODE VOAS & TAP DETECTORS

### TABLE OF CONTENTS

Precision VOAs .....	3 - 4
Thin Film Tap Detectors .....	5 - 6
Precision VOAs with Power Monitoring .....	7 - 8
Chassis Specifications .....	9 - 10

DiCon Fiberoptics' Precision Variable Optical Attenuators (VOAs) allow a precise amount of attenuation to be added to an optical path, while DiCon's Thin Film Tap Detectors monitor the optical power level. These utilize optical designs that affect all modes equally, making them ideal for multimode fiber applications.

- Optimized for multimode fiber
- Stable performance, independent of mode fill condition
- Proven, reliable design

#### PRECISION VOA

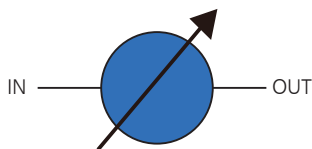

#### THIN FILM TAP DETECTOR

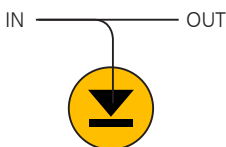

#### PRECISION VOA WITH POWER MONITORING

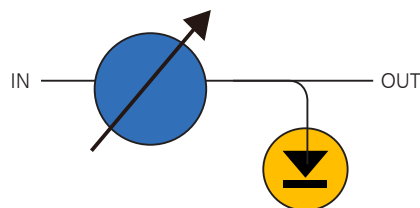

# GP600 - MULTIMODE ATTENUATORS

## PRECISION VOA

DiCon's Precision Variable Optical Attenuator (VOA) allows for a specified amount of attenuation to be added to an optical path by precisely positioning a variable neutral density filter in the light path.

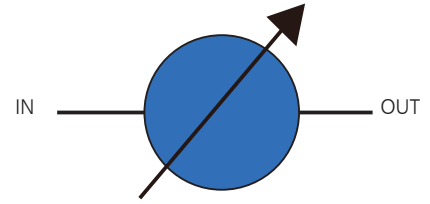

- Ideal for Multimode Fiber
- Stable Attenuation, Independent of Mode Fill Condition
- 30 or 60 dB Attenuation Range

## OPTICAL SPECIFICATIONS (Specifications without connectors at approx. 23°C.)

Parameter	Rating	
Attenuation Range (dB)	0 - 30 or 0 - 60	
Tuning Resolution (dB)	0 - 30 dB	0.01 Max
	0 - 60 dB	0.04 Max (0 - 40 dB)
Attenuation Accuracy (dB)	0 - 30 dB	± 0.2 Max. (0 - 20 dB)
	0 - 60 dB	± 0.2 Max. (0 - 30 dB) // ± 0.3 Max. (30 - 40 dB)
Excess Loss, Max. (dB)	0.8 Typ. // 1.3 dB Max.	
Flatness (dB)	± 0.1 Max	
Repeatability (dB)	± 0.1 Max	
Back Reflection (dB)	-20 Max.	
Tuning Speed	100 ms Min. // 1700 ms Max.	
Optical Power	300 mW Max.	
Fiber Type	50 um core // 62.5 um core multimode	

# GP600 - MULTIMODE ATTENUATORS

## PRECISION VOA ORDERING INFORMATION

**GP600** -  -  -  -  -  -  -  -  -  -

**Product Code**

**GP600** GP600 System

**Chassis Type**

- 1U** 1U Rackmount
- 2U** 2U Rackmount
- 4U** 4U Rackmount
- 4E** 4U Extended Rackmount
- B** Benchtop Chassis

**Product Type**

**NAT** Precision VOA

**Configuration**

**X** X = # of Channels

**Attenuation Range**

- 30** 0 - 30 dB attenuation range
- 60** 0 - 60 dB attenuation range

**Wavelength Range**

- 8** 850 nm
- 9** 980 nm
- 13** 1310 nm
- 15** 1550 nm
- 8/13** 850 nm & 1310 nm

**Fiber Type**

- 50** 50/125 um multimode fiber
- 62** 62.5/125 um multimode fiber

**Connector Type**

- FC** FC/PC
- LC** LC/PC
- SC** SC/PC
- ST** ST/PC
- E2000/APC** E2000/APC

**Connector Location**

- F** Front Panel
- R** Rear Panel

# GP600 - MULTIMODE ATTENUATORS

## THIN FILM TAP DETECTOR

DiCon's Thin Film Tap Detectors enable the optical power level to be monitored by tapping off a small percentage of light with a thin film partial reflector, which directs the light to a photodetector.

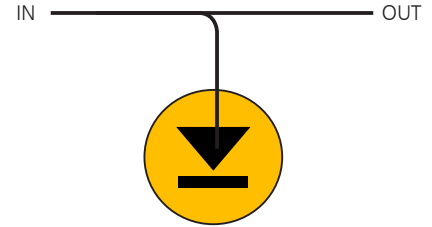

- Ideal for Multimode Fiber
- Stable Performance, Independent of Mode Fill Condition
- High Density Design to Minimize Rack Space

## OPTICAL SPECIFICATIONS (Specifications without connectors at approx. 23°C.)

Parameter	Rating	
	Tap %	5%
Insertion Loss, Max. (dB)	0.8	1.0
Measurable Input Power (dBm)	-27 to 13	-30 to 10
Relative Measurement Accuracy (dB)	± 0.3 Max.	
Measurement Resolution (dBm)	0.1	
Back Reflection (dB)	-20 Max.	
Optical Power	300 mW Max.	
Fiber Type	50 um core // 62.5 um core multimode	

# GP600 - MULTIMODE ATTENUATORS

## THIN FILM TAP DETECTORS ORDERING INFORMATION

**GP600** -  -  -  -  -  -  -  -  -  -

### Product Code

**GP600** GP600 System

### Chassis Type

**1U** 1U Rackmount  
**2U** 2U Rackmount  
**4U** 4U Rackmount  
**4E** 4U Extended Rackmount  
**B** Benchtop Chassis

### Product Type

**TD** Tap Detector

### Configuration

**X/Y** X = # of Channels, Y = Tap Ratio %

### Sensitivity

**S** Standard

### Wavelength Range

**8** 850 nm

### Fiber Type

**50** 50/125 um multimode fiber  
**62** 62.5/125 um multimode fiber

### Connector Type

**FC** FC/PC  
**LC** LC/PC  
**SC** SC/PC  
**ST** ST/PC  
**E2000/APC** E2000/APC

### Connector Location

**F** Front Panel  
**R** Rear Panel

# GP600 - MULTIMODE ATTENUATORS

## Precision VOA with Power Monitoring

DiCon's Precision VOA allows for a specified amount of attenuation to be added to an optical path by precisely positioning a variable neutral density filter in the light path. The optical power is then monitored with a Thin Film Tap Detector.

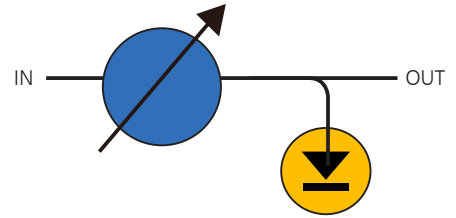

- Ideal for Multimode Fiber
- Stable Performance, Independent of Mode Fill Condition
- Open Loop Control

## OPTICAL SPECIFICATIONS (Specifications without connectors at approx. 23°C.)

Parameter		Rating	
Tap %		5%	10%
Excess Loss, Max. (dB)		2.1 Max.	2.3 Max.
Measurable Power (dBm)		-27 to 13	-30 to 10
Power Measurement Resolution (dBm)		0.1	
Attenuation Range (dB)		0 - 30 or 0 - 60	
Tuning Resolution (dB)	0 - 30 dB	0.01 Max	
	0 - 60 dB	0.04 Max (0 - 40 dB)	
Attenuation Accuracy (dB)	0 - 30 dB	± 0.2 Max. (0 - 20 dB)	
	0 - 60 dB	± 0.2 Max. (0 - 30 dB) // ± 0.3 Max. (30 - 40 dB)	
Flatness (dB)		± 0.1 Max	
Repeatability (dB)		± 0.1 Max	
Back Reflection (dB)		-20 Max.	
Tuning Speed		100 ms Min. // 1700 ms Max.	
Optical Power		300 mW Max.	
Fiber Type		50 um core // 62.5 um core multimode	

# GP600 - MULTIMODE ATTENUATORS

## VOA WITH POWER MONITORING ORDERING INFORMATION

**GP600** -  -  -  -  -  -  -  -  -  -

Product Code	
<b>GP600</b>	GP600 System
Chassis Type	
<b>1U</b>	1U Rackmount
<b>2U</b>	2U Rackmount
<b>4U</b>	4U Rackmount
<b>4E</b>	4U Extended Rackmount
<b>B</b>	Benchtop Chassis
Product Type	
<b>NET</b>	VOA with Power Monitoring
Configuration	
<b>X/Y</b>	X = # of Channels, Y = Tap Ratio %
Attenuation Range	
<b>30</b>	0 - 30 dB attenuation range
<b>60</b>	0 - 60 dB attenuation range
Wavelength Range	
<b>8</b>	850 nm
Fiber and Jacket Type	
<b>50</b>	50/125 um multimode fiber
<b>62</b>	62.5/125 um multimode fiber
Connector Type	
<b>FC</b>	FC/PC
<b>LC</b>	LC/PC
<b>SC</b>	SC/PC
<b>ST</b>	ST/PC
<b>E2000/APC</b>	E2000/APC
Connector Location	
<b>F</b>	Front Panel
<b>R</b>	Rear Panel



# GP600 - CHASSIS

## ELECTRICAL SPECIFICATIONS

Parameter		Rating
Control	Interface	Ethernet 10/100 Base T and RS-232
	Ethernet/RS-232 Switch	Manual slide switch on rear to select control method
Power Supply	Voltage	100 - 240 VAC
	Frequency	50/60 Hz
	On/Off Switch	2-position toggle on rear
Connectors	Ethernet	RJ45 female receptacle
	RS-232	DB9 female receptacle
	Power Supply	IEC 60320 C13 female receptacle (standard AC connector)
	Location	Rear of chassis
Power LED	On State	GP600 is on (Receiving power and power switch is in on position)
	Off State	GP600 is off (Not receiving power, or power switch is in off position)
	Location	Front of chassis

### Benchtop Chassis

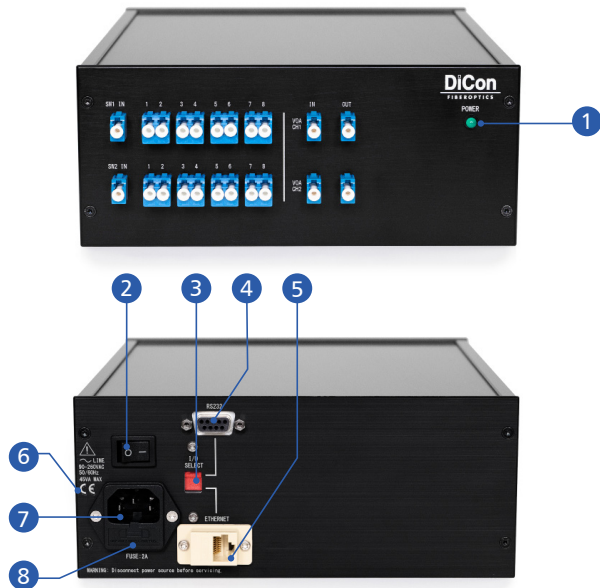

- 1 Power LED
- 2 Rocker Switch (Toggle to turn unit on and off)
- 3 I/O Select (Switch used to select the one active interface)
- 4 RS-232, DB9 Connector
- 5 Ethernet, RJ45 Connector
- 6 CE Mark
- 7 Power Cord Inlet
- 8 Replaceable Fuse

# GP600 - CHASSIS

## MECHANICAL SPECIFICATIONS (Dimensions in inches (in) are approximate for reference.)

Chassis	Height		Width		Depth	
	mm	in	mm	in	mm	in
1U	44	1.7	483	19	342	13.5
2U	88	3.5	483	19	435	17.1
4U	177	7.0	483	19	435	17.1
4U Extended (4E)	177	7.0	483	19	554	21.8
Benchtop (B)	88	3.5	210	8	250	9.8

## MAXIMUM # OF CONNECTORS

Chassis Size	Panel	FC FC/APC	ST ST/APC	SC SC/APC	LC LC/APC
1U	Front	43	43	57	85
	Rear	11	11	21	24
2U	Front	73	73	89	145
	Rear	55	55	72	121
4U	Front	225	225	240	381
	Rear	190	190	201	288
Benchtop	Front	37	37	60	81
	Rear	24	24	32	56

## ENVIRONMENTAL SPECIFICATIONS

Parameter	Rating
Operating Temp	0 to 50°C
Storage Temp	-20 to 60°C
Relative Humidity	0% to 80% non-condensing